

OWEN L800 / L800U

LED opgradering / LED lighting upgrade / LED upgrade /
LED uppgradering

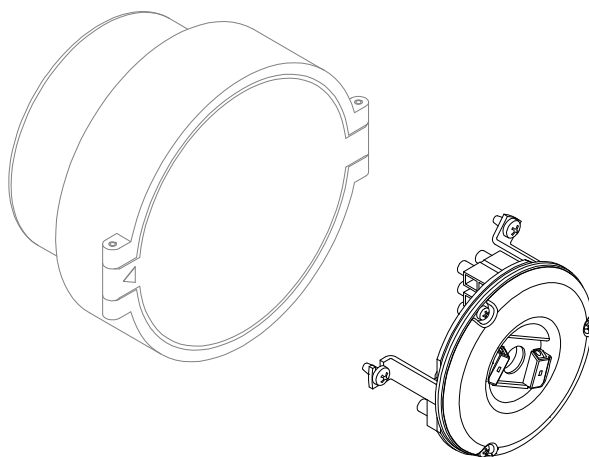

Monteringsvejledning / Mounting instructions /
Installationsanleitung / Installationsinstruktioner

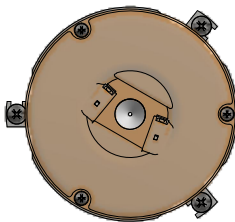
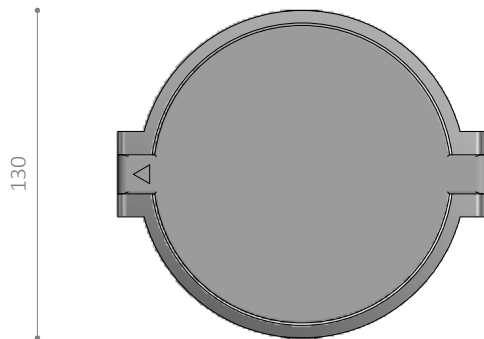

Værktøj / Tool / Werkzeug / Verktyg:



2 mm

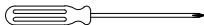

PH2

1



2 mm

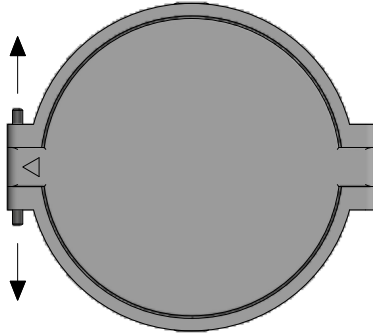

2

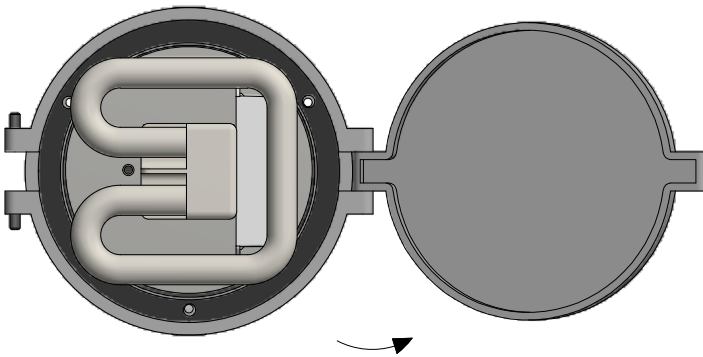

3

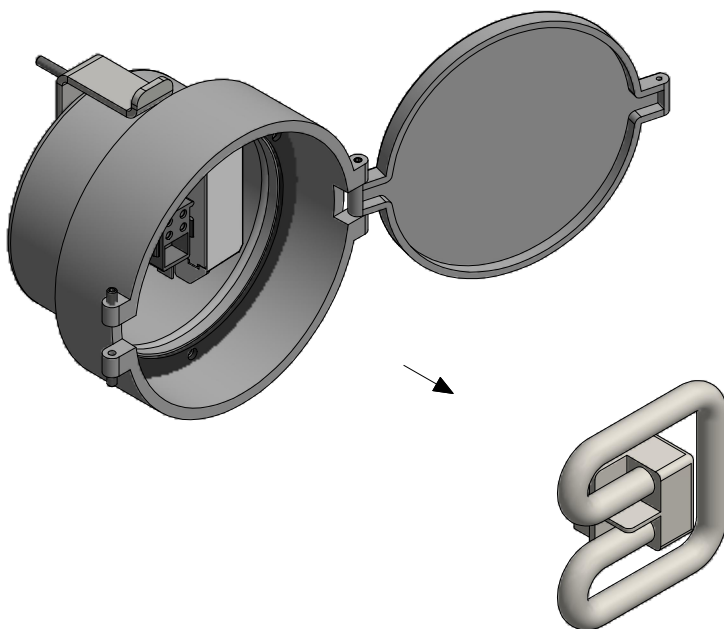

4



PH2

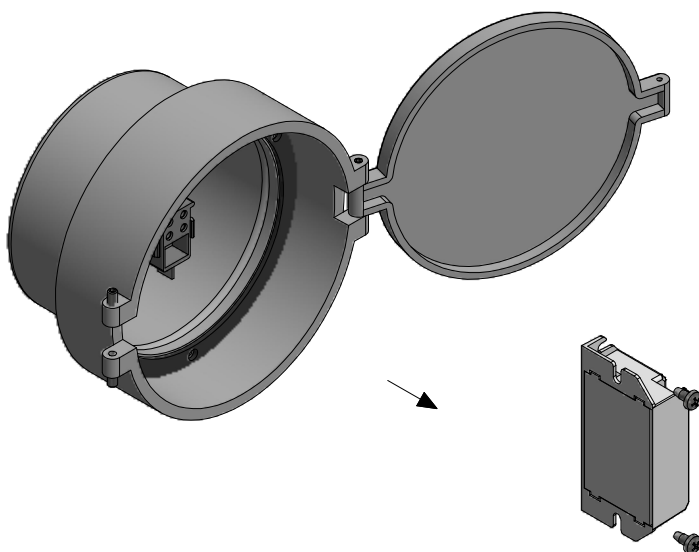

5



PH2

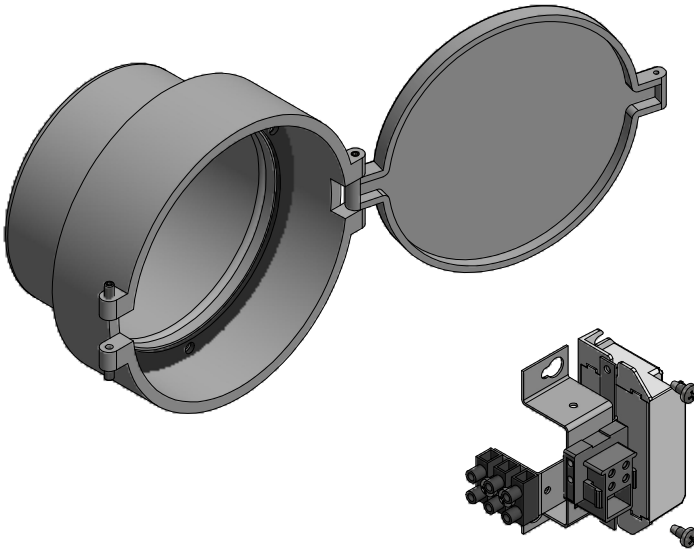

5

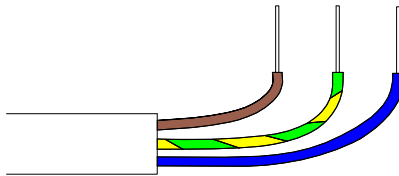
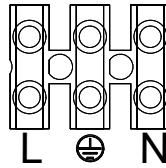
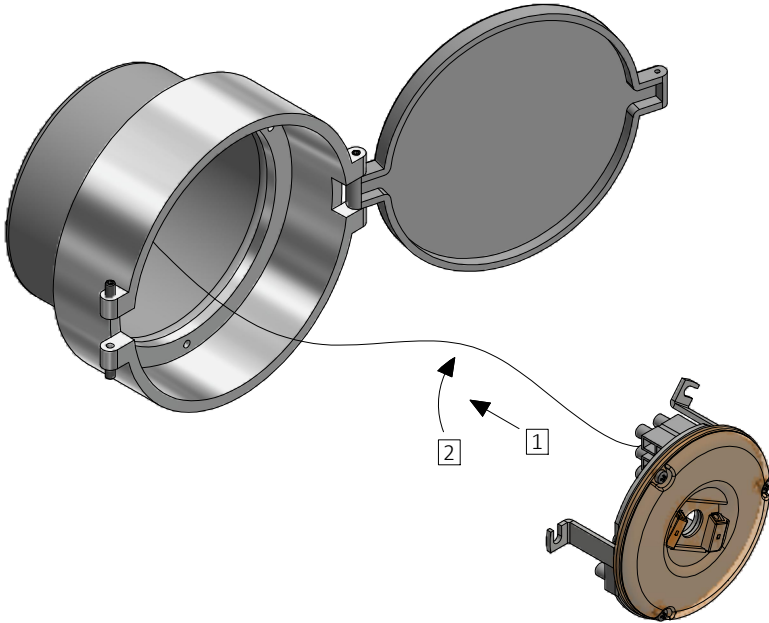

6

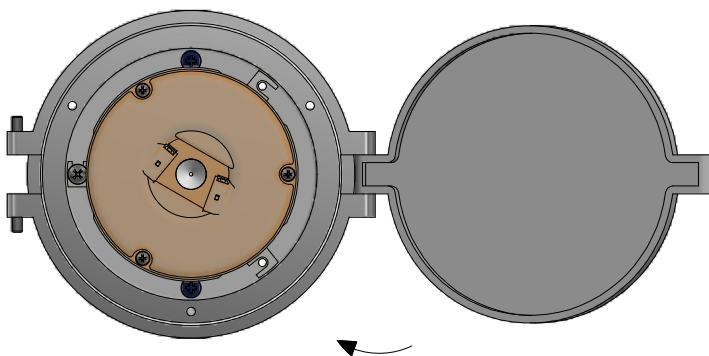

7



2 mm

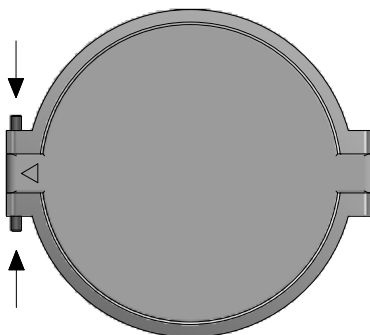



LED



Isolationsklasse I / Insulation class I / Schutzklasse I / Isolationsklass I



0,1 kg



Se monteringsvejledning / See mounting instructions / Siehe Installationsanleitung / Se Installationsinstruktioner



Montering/udskiftning må kun udføres af producenten eller aut. el-installatør / Installation/replacement must only be carried out by the manufacturer or by an electrician / Die Installation/der Austausch darf nur vom Hersteller oder von einem Elektriker durchgeführt werden / Installation / utbyte får endast utföras av tillverkaren eller av en behörig elektriker

Lampas